

Method and process for combustion synthesized supported cobalt catalysts for fixed bed Fischer Tropsch reaction

Center for Sustainable Technologies
Indian Institute of Science
Bangalore

IDF presentation to the committee – 15 September 2015

- Background
- Catalysts development
- Catalyst characterization
- Fischer Tropsch reaction
- Conclusion

Background

- FT process converts syngas (CO and H₂) to higher hydrocarbons via catalytic reactions.
- The choice and properties of the catalyst have major impact on the reaction rates and product selectivity.
- Conventionally, supported catalysts have been used for several industrial reactions (SMR, hydrocracking, oxygenation, **Fischer Tropsch**)
- The functionality of the catalyst drives the product output, economics of the process and product

Liquid fuel – FT synthesis

Initially planned activity

- Establish fixed bed FT reactor
- Use of commercial catalyst for arriving at base level data
 - To conduct FT experiments using commercially available catalysts
 - Product analysis, its response to reactor conditions and also the catalyst functionality to varying feed gas conditions have to be investigated

- Commercial catalyst
 - Efforts towards using commercial catalysts for base line scenario failed
 - All the companies we approached were not ready to share their catalyst with R and D groups
- In-house development of catalyst
 - Necessary actions taken towards in-house development of the catalyst

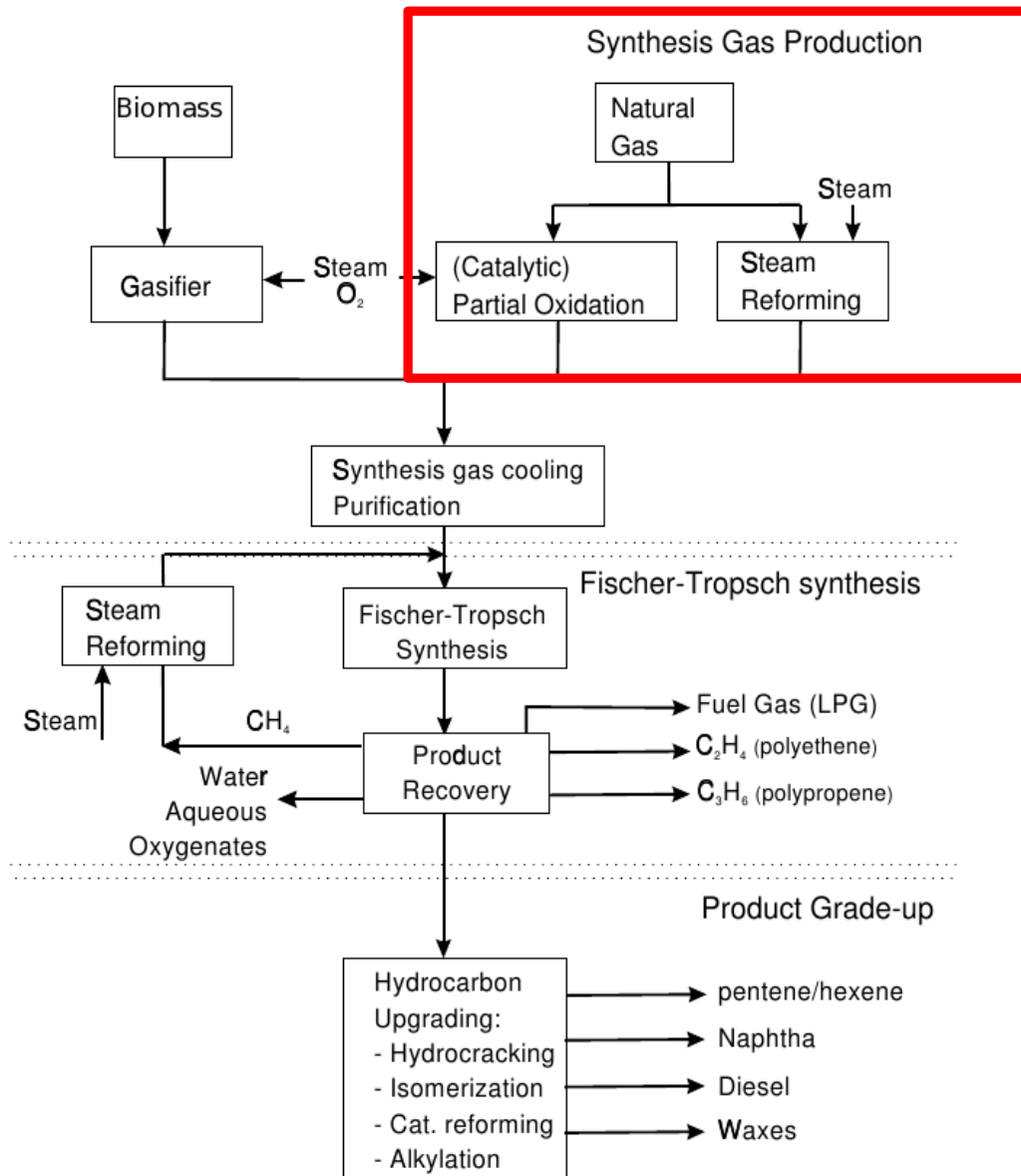

- The FT reactors can be categorized into high temperature Fischer Tropsch (**HTFT**) reactors (operating at 320-350 °C) and low temperature Fischer Tropsch (**LTFT**) reactors (operating at 220-250 °C).

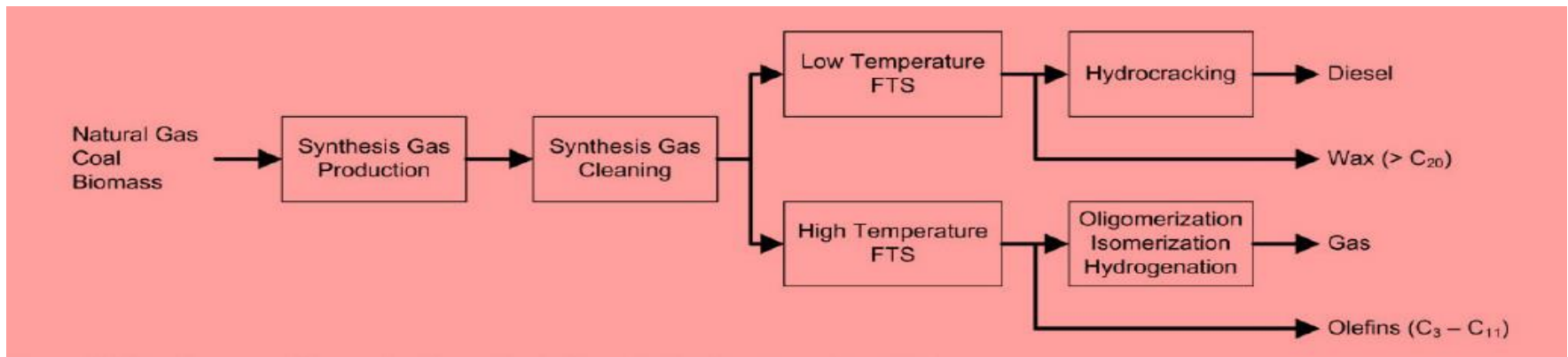

- In HTFT, gaseous products are formed in moving bed reactors and no liquid phase is present outside the catalyst particles. Formation of liquid phase in the HTFT fluidized bed reactors will lead to serious problems due to particle agglomeration and loss of fluidization.
- In LTFT, liquid products are also present under the process conditions.

THE FIXED BED REACTOR OPERATION

- Fixed bed advantage

- Simple to operate and can be used at wide temperature ranges
- Can be used conveniently, irrespective of whether, FT products are gaseous or liquids
- Any gas contaminants get narrowed down along the length, causing only temporary upset, if at all
- Fixed bed reactors are most suitable for low temperature applications, making the use of Co catalyst an ideal reactor-catalyst combination

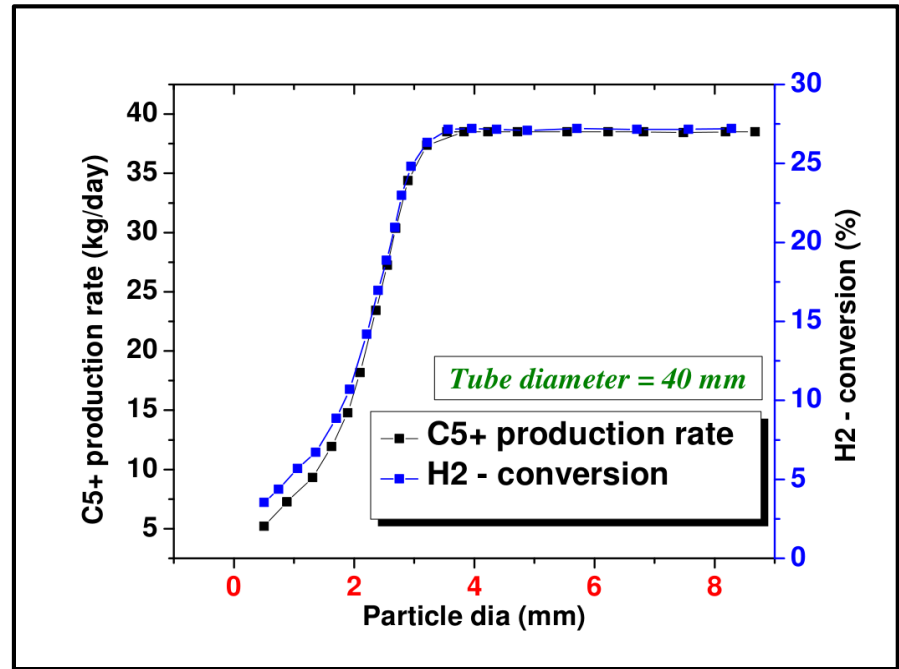
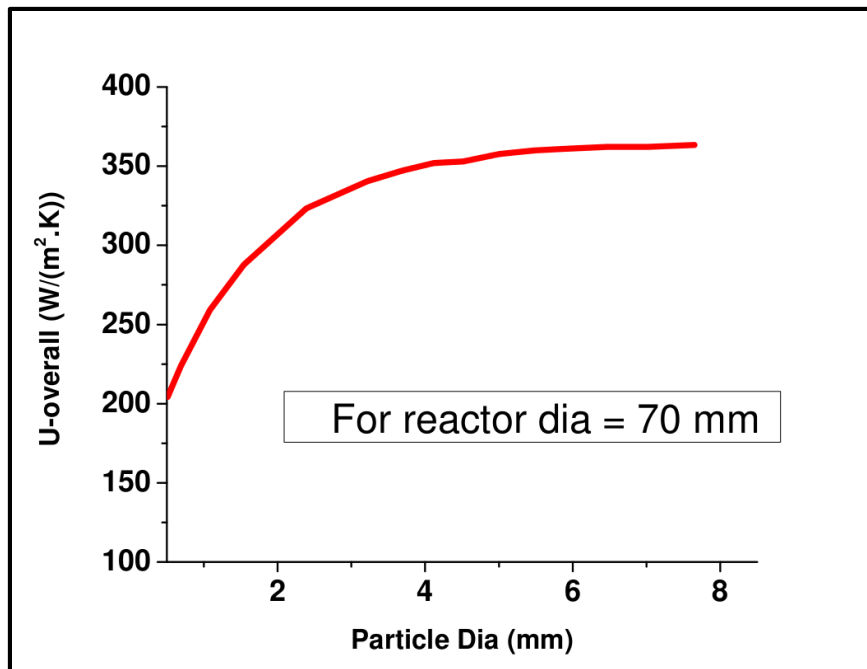

FT reaction catalysis

- Intended catalyst features
 - High activity
 - High C5+ selectivity
 - Resistance to oxidation and coking
 - Endurance
- Principal FT catalyst properties
 - High metal loading (20 – 30 wt.%)
 - High degree of reduction
 - Moderate dispersion (15 – 20%)
 - Optimum crystallite size (15 – 25 nm) and uniform metal distribution
 - Addition of promoters

An obvious question arises, if one can **tailor** these catalysts to effectively catalyze the reaction under consideration

Synthesis of catalyst

Catalysts are generally synthesized by Incipient Wetness Impregnation (IWI) and Solution Combustion Method (SCM).

INCIPIENT WETNESS IMPREGNATION

- The active metal precursor is dissolved in an aqueous or organic solution to allow for diffusion and capillary action.
- If pore volume of catalyst support is same or less than that of solution volume, then solution is drawn into pores by capillary action.
- It is then dried or calcinated to remove volatile compounds .
- The maximum loading is limited by the solubility of the precursor in the solution.

SOLUTION COMBUSTION METHOD

- In SCM, a fuel and a precursor is taken in a solvent (usually water) and the support is soaked in it.
- Both get loaded onto the support.
- During calcination, combustion takes place leaving behind the active catalyst in the form of oxide on the support.
- For synthesis, Urea was chosen as fuel.
- Fuel to Precursor ratio (ϕ) of 1.6 was chosen according to the following equation for Cobalt Catalyst

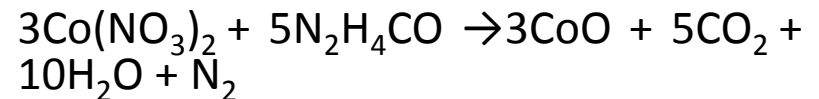

CATALYST SYNTHESIS PROCEDURE

- Synthesis procedure has a pronounced effect on the catalyst properties, directly affecting the reaction activity and selectivity
- Basic step includes introducing the metal precursor into high surface area support, followed by its calcination.
- For FT reaction, the synthesized metal oxide needs to be further reduced to its zero valent state.
- Metal incorporation is most commonly achieved by Incipient Wetness Impregnation (IWI)

IWI SYNTHESIS PROCEDURE

- Characteristics of catalysts using IWI Synthesis procedure
 - Low metal reducibility
 - Large crystallite sizes, mostly clustered metal sites (20 - 30 nm)
 - Low metal dispersion (10%)
 - Large rates of deactivation
 - Non-homogeneous deposition over the support surface

Solution Combustion Method (SCM)

- Applied to large number of metal oxides and nano-size range particles.
- More recently, supported catalysts were synthesized for TWC, photocatalysts, OSC, etc.
- Major drawback includes, synthesizing supported catalysts with high metal loading ($>5\%$), since the highly exothermic redox reaction results in powdered catalysts. Thus limiting the maximum metal loading to $<10\%$.

In this work, supported catalysts were synthesized by SCM with metal loading of 20% over support extrudes for direct application to fixed bed FT reactors support interaction & its influence on FT activity

EXPERIMENTAL PROCEDURE

- For SCM catalysts, aqueous solution of a fuel and metal precursor was prepared with unity equivalence ratio
- Cobalt nitrate hexahydrate ($\text{Co}(\text{NO}_3)_2 \cdot 6\text{H}_2\text{O}$) was used as the metal precursor
- Hexamethylenetetramine $\text{C}_6\text{H}_{12}\text{N}_4$ was used as the fuel
- IWI catalysts were synthesized in a single step (one-step complete impregnation + calcination @ 700 K for 4 hours)
- Properties of SCM catalysts were compared with IWI catalysts

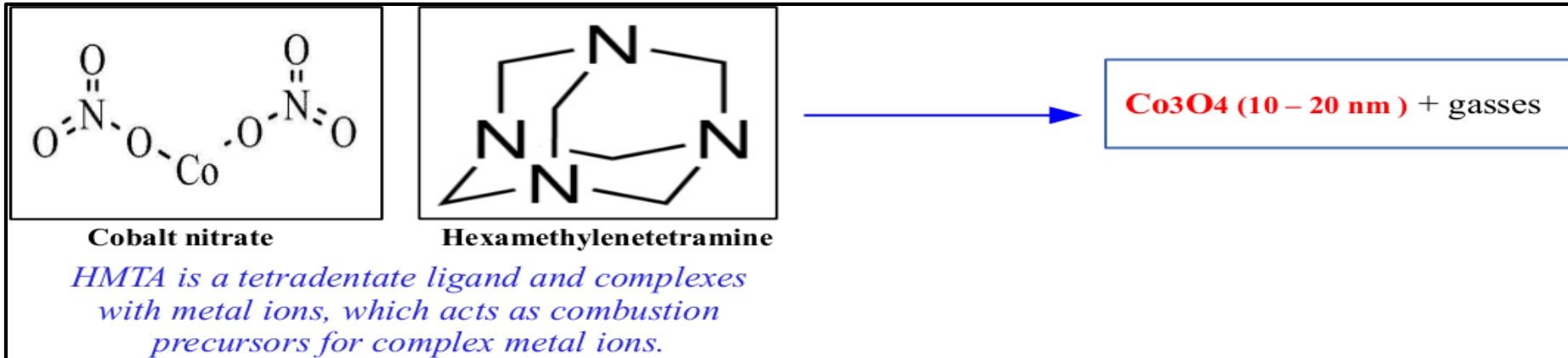

EXPERIMENTAL SETUP

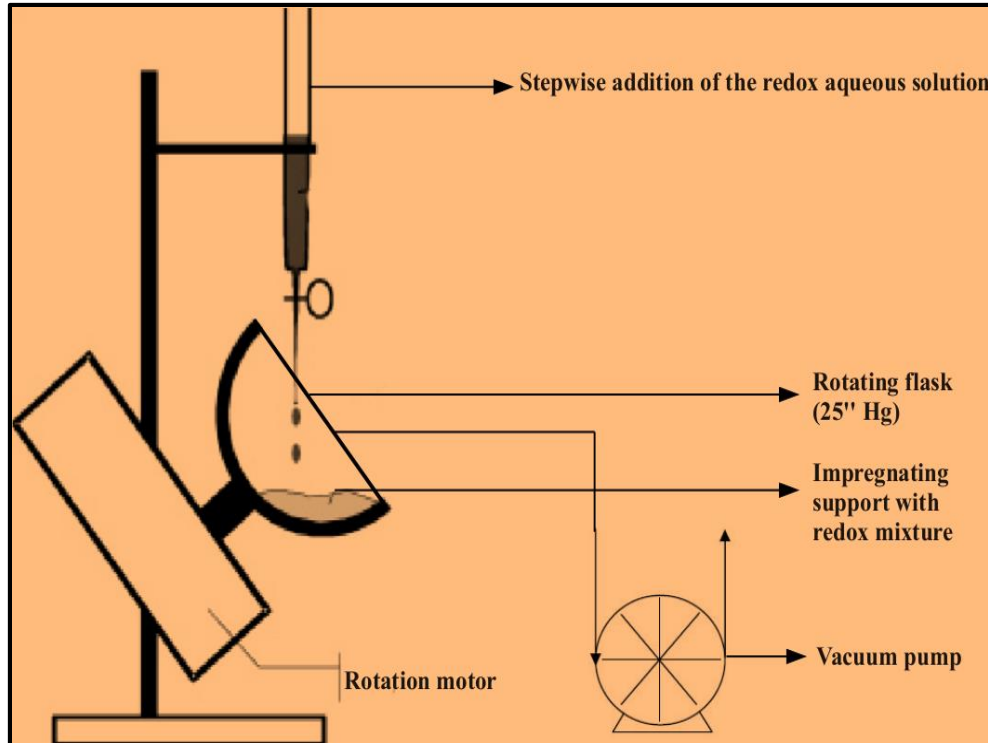

- The setup enables molecular level of precursor mixing
- Homogeneous distribution of metal-oxide across the support-framework
- Deposition over varying particle size support
- Enhanced level of metal loading addition (0.5% - 30%)
- Creating an inert atmosphere in the synthesis vessels, enables prevention of oxide formation and direct emergence of metal from the precursor deposition
- The setup can be easily scaled-up for large scale synthesis of catalysts used in a variety of applications

Support matrix sizes

250 cpsi honeycomb

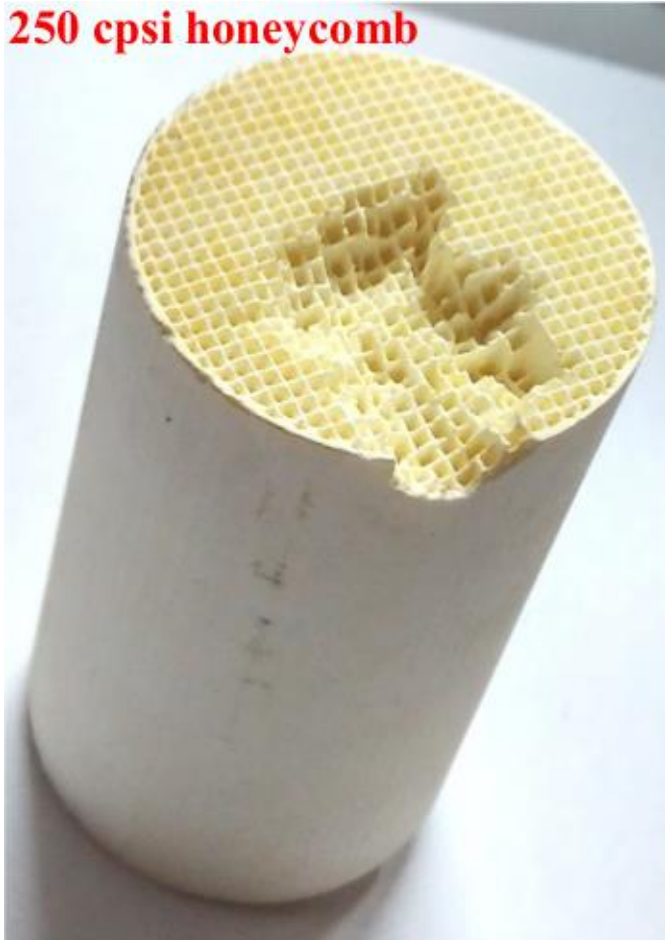

3 mm pellets



1 mm spheres



CATALYST CHARACTERIZATION TECHNIQUES

- Combustion temperature measurement
- Simultaneous thermal analysis (DTA-TGA)
- Fourier Transform infrared spectroscopy (FT-IR)
- X-ray diffraction (XRD)
- Temperature programmed reduction and desorption (TPR- TPD)
- X-ray photoelectron spectroscopy

Combustion thermodynamics

- F/O should be sufficient enough to generate enough energy, after ignition, to completely decompose metal PC and any organic matter - clean catalyst.
- Identification of temperature profile of the reaction is crucial for understanding the combustion behavior.

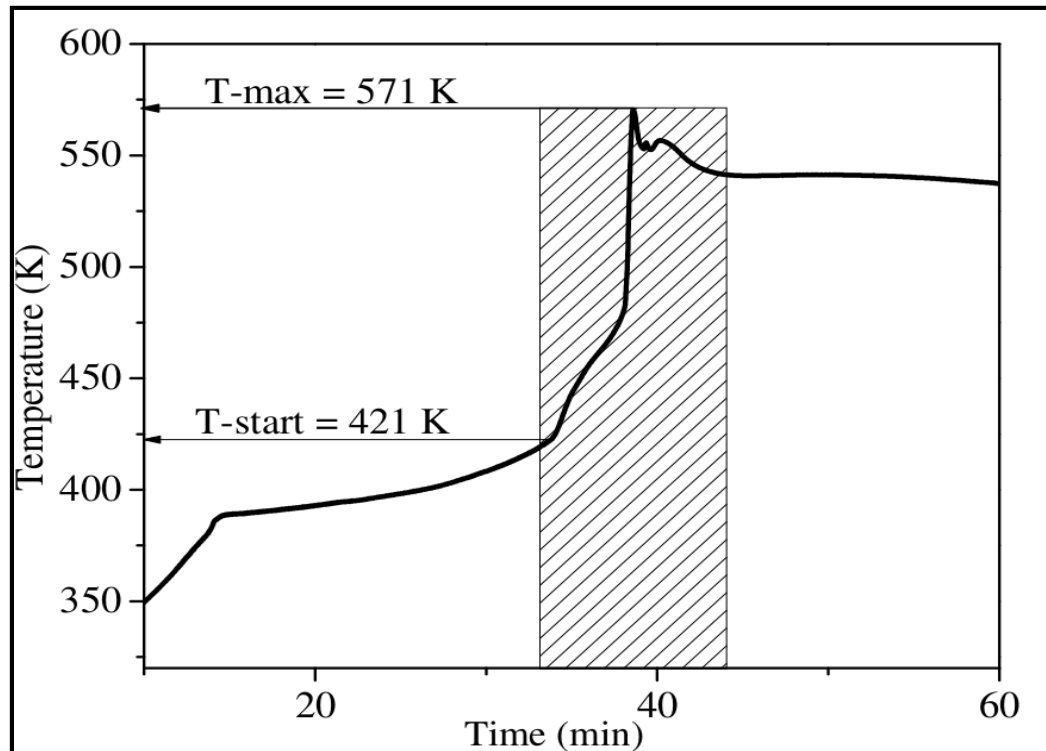

Two stages of combustion observed

- **1st stage** (421 K to 480 K) initiation of surface combustion reaction, with a slope of 15 K/min
- **2nd stage**, from 480 K to 571 K - redox reaction of bulk NO^3 - and fuel, with a slope of 200 K/min

X-ray diffraction

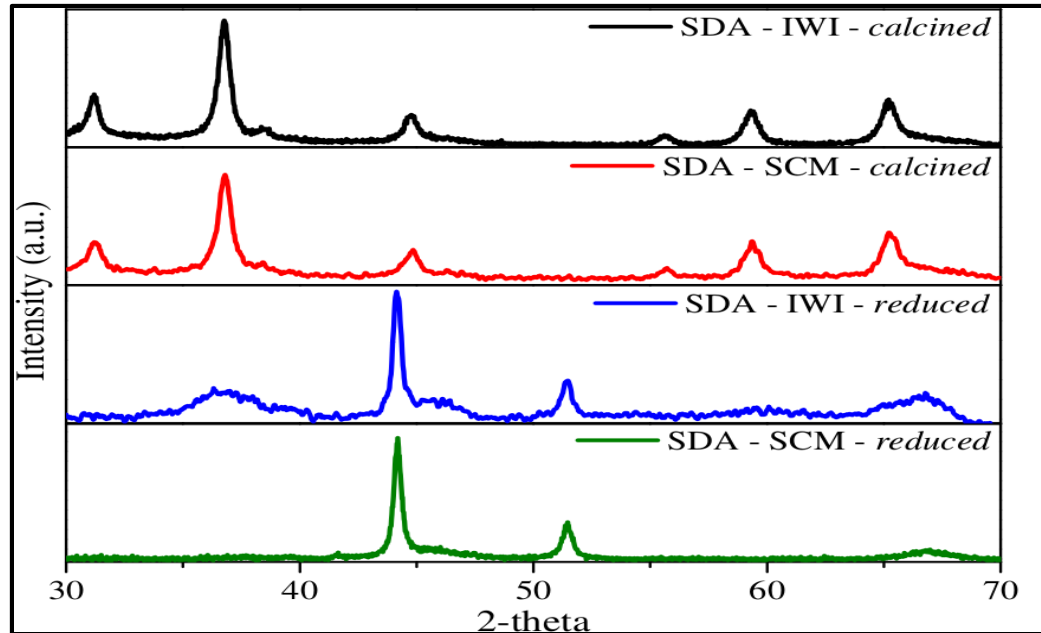

Catalyst	d-Co ₃ O ₄ (nm)	d-Co (nm)
SDA - IWI	14.1	26
SDA - SCM	10.7	18.2

Temperature programmed reduction

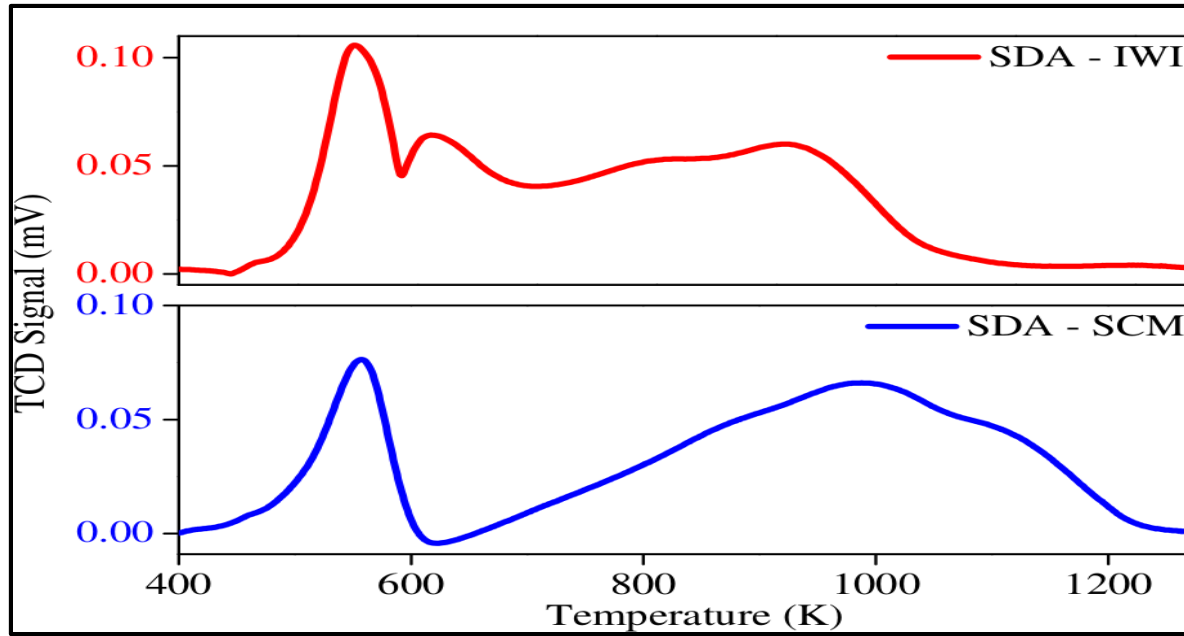

Catalyst	Reduction temperature			Reduction degree	Dispersion
	T1 (K)	T2 (K)	T3 (K)	(%)	(%)
SDA – IWI	547	611	909	81	12.1
SDA – SCM	557		986	92	16.1
Co ₃ O ₄ - std	512	574			

X-ray photoelectron spectroscopy

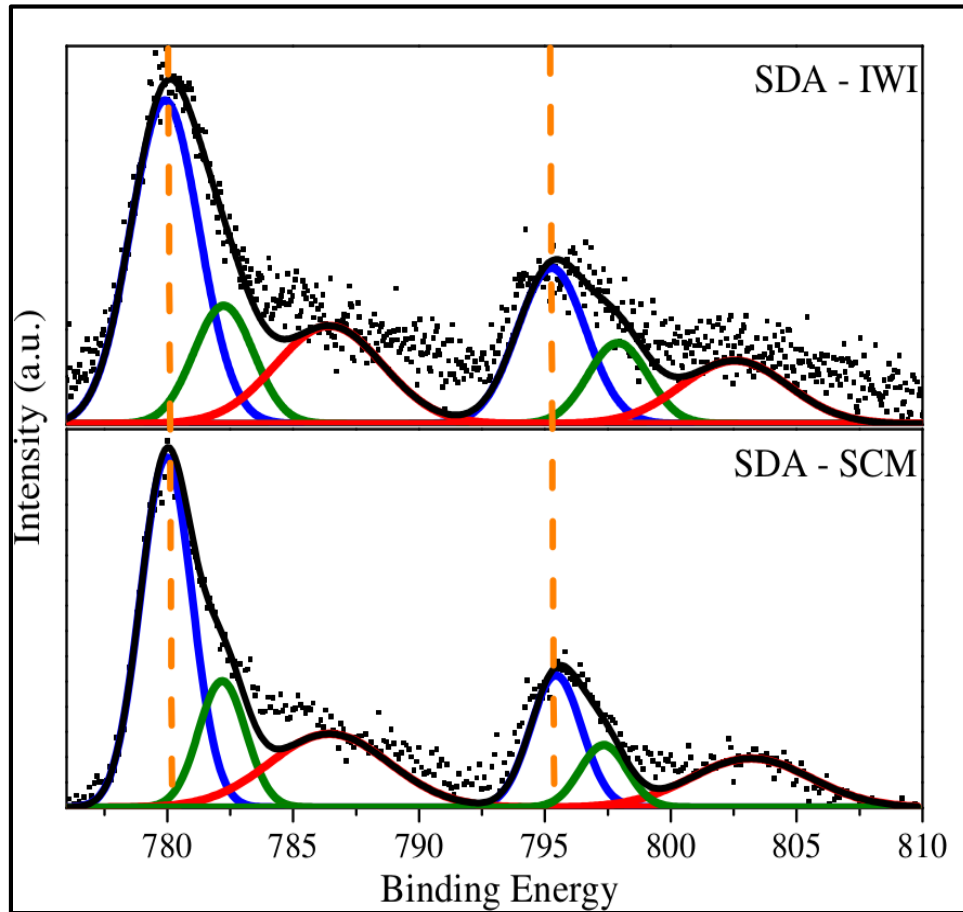

- The Co-2p_{3/2} component at 779.9 eV assigned to Co₃O₄
- The second peak at 783 eV assigned to CoO
- Shake-up satellite peaks observed at 6 - 7 eV higher than the main peak
- Higher intensity of shake-up satellites correspond to larger concentrations of CoAl₂O₄, since cobalt aluminates have signatures of strong shake-up satellite peaks

Catalyst	Co _{2p3/2} (eV)	Spin orbital splitting (eV)	I-Co _{2p3/2} /I-shakeup	I _{Co} /I _{Al}
SDA - IWI	779.9	15.6	2.5	1.3
SDA – SCM	779.7	15.4	5.7	2.2
Co ₃ O ₄ – std	779.9	15.0	-	

- Combustion synthesized catalysts have reduced formation of cobalt-support compounds and hence lower metal support interaction
- Lower metal support interaction result in higher catalyst reducibility and higher metal dispersion
- Highest dispersion is obtained for combustion synthesized catalysts. Metal dispersion as observed from XPS analysis increases for combustion synthesized cobalt catalysts
- Addition of silica reduces the metal support interaction, resulting in larger number of active Co⁰ sites.
- H₂ TPR-TPD results support the XPS observations.

FT process

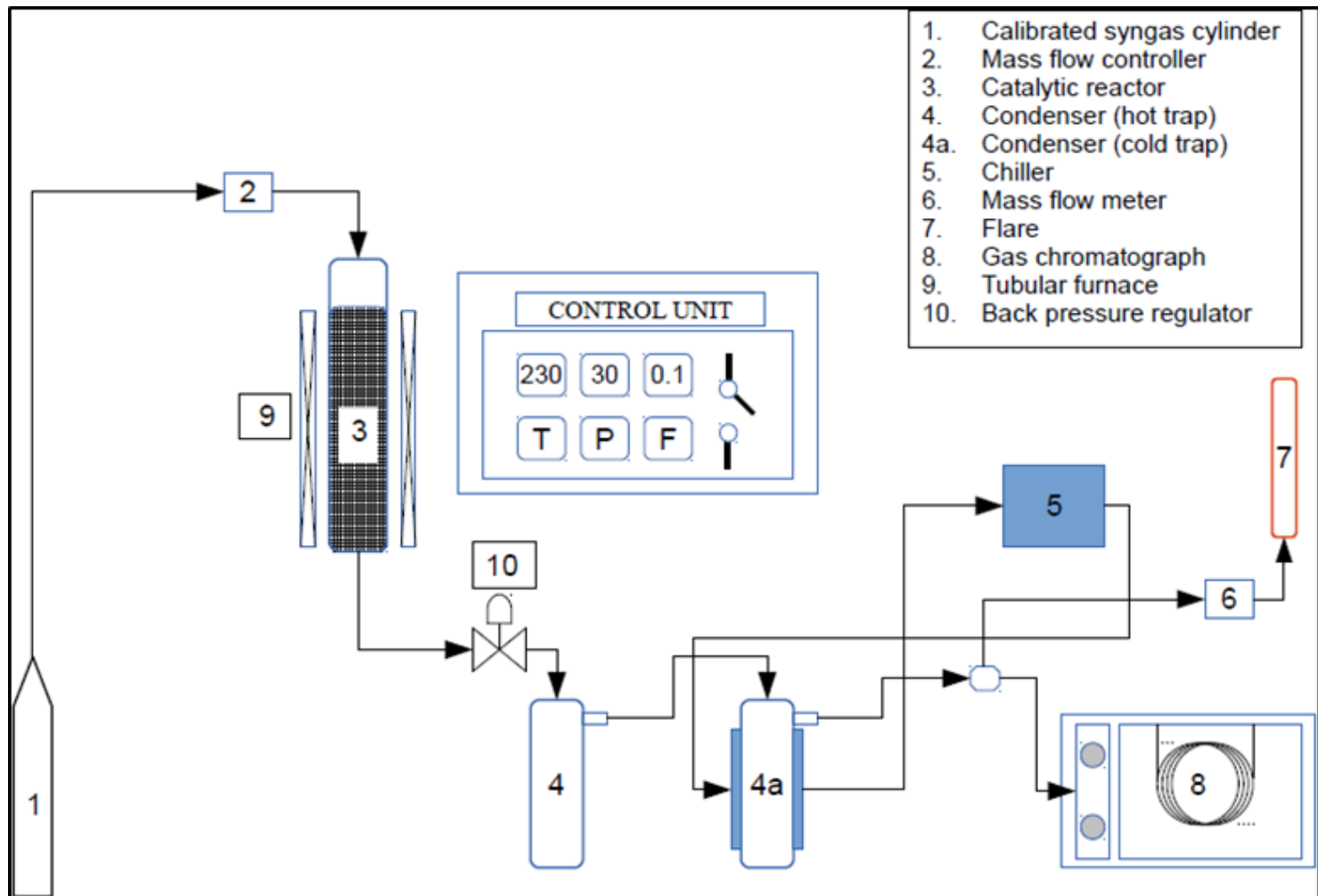

Fischer Tropsch reaction

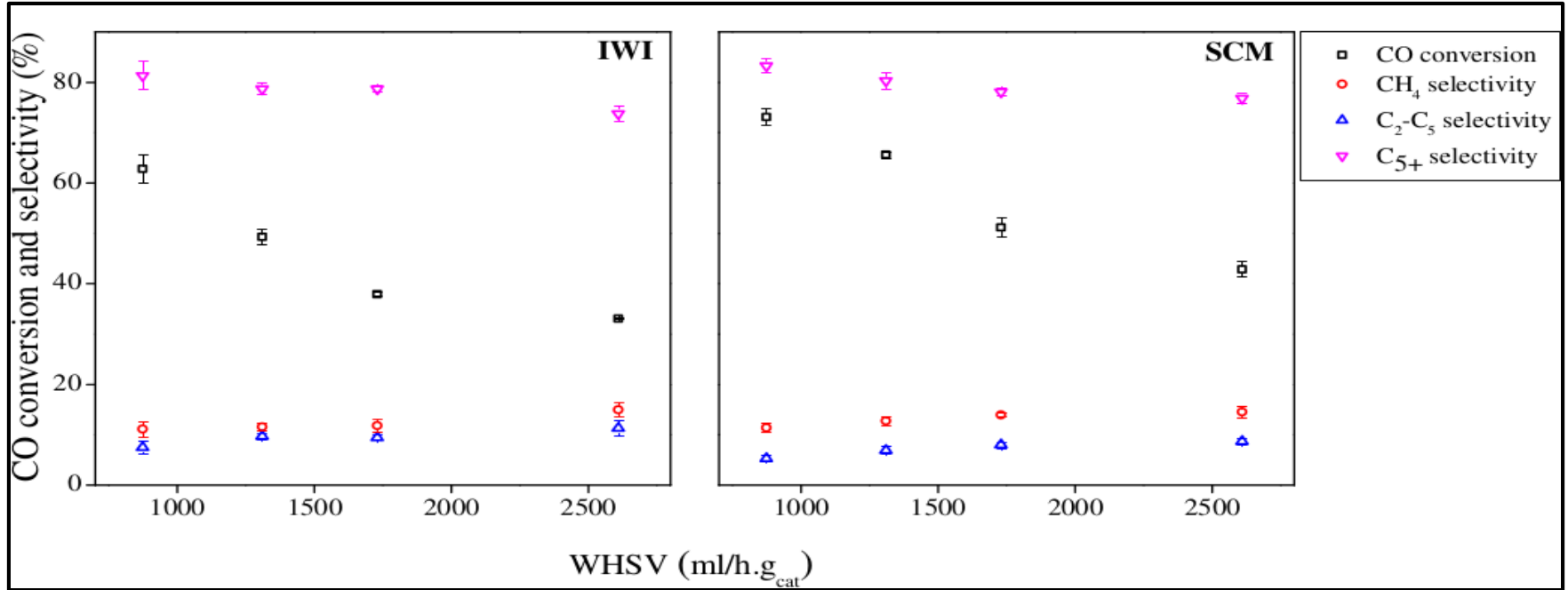

- Highest conversion is recorded for SDA-SCM catalysts
- Increase in C₅₊ selectivity is only marginal for CS catalysts.
- Higher C₂-C₅ selectivity for SDA catalysts indicate zeolite like behavior for SDA supported catalyst.
- A decrease in the space velocity from 2610 ml/(h*g_{cat}) to 873.3 ml/(h*g_{cat}) results in the increase of yield from 0.28 g_{-C5+}/g_{-syngas} to 0.52 g_{-C5+}/g_{-syngas}, indicating 86% increase in the product yield

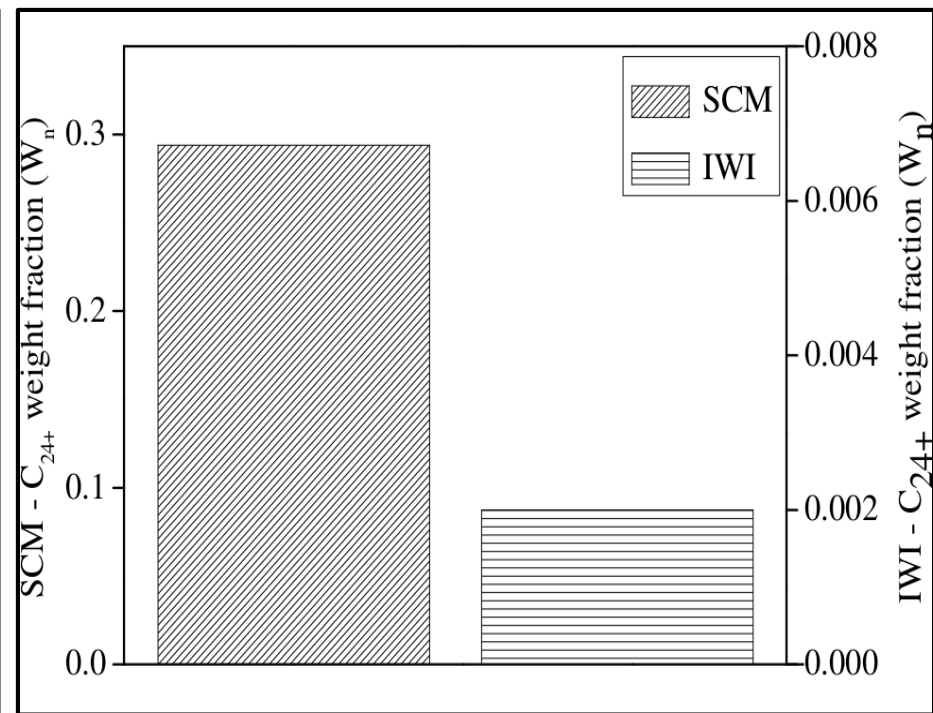
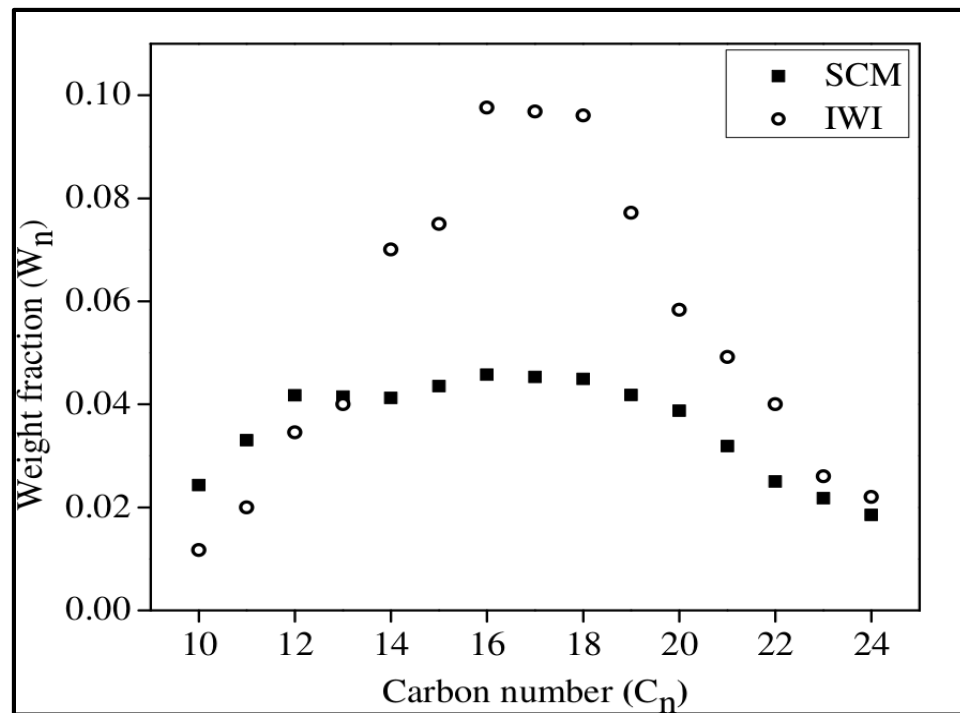

- Combustion synthesized catalysts resulted in formation of heavier waxes
- CS catalysts, show formation of longer chain hydrocarbons over the catalyst surface
- The longer chain hydrocarbons on the catalyst surface is directly attributed to higher metal dispersion and lower metal support interaction

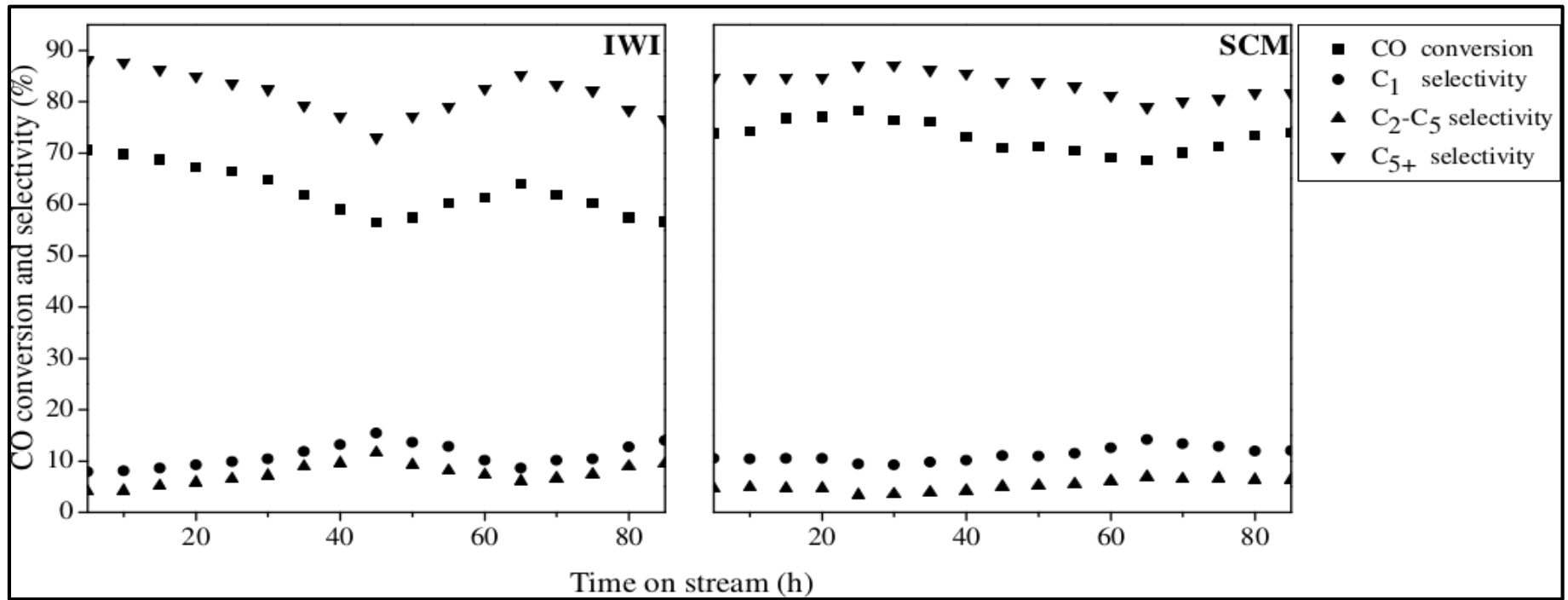

- For 80 hour experimental run, the FT activity and selectivity remained un-affected for SCM catalysts, indicating no catalyst deactivation.
- For IWI catalysts, the CO conversion dropped from 70.6% to 56.6%, showing a 25% reduction in FT activity.
- Higher catalyst stability for combustion synthesized catalysts achieved with respect to FT reactions.

Comparison with other catalysts

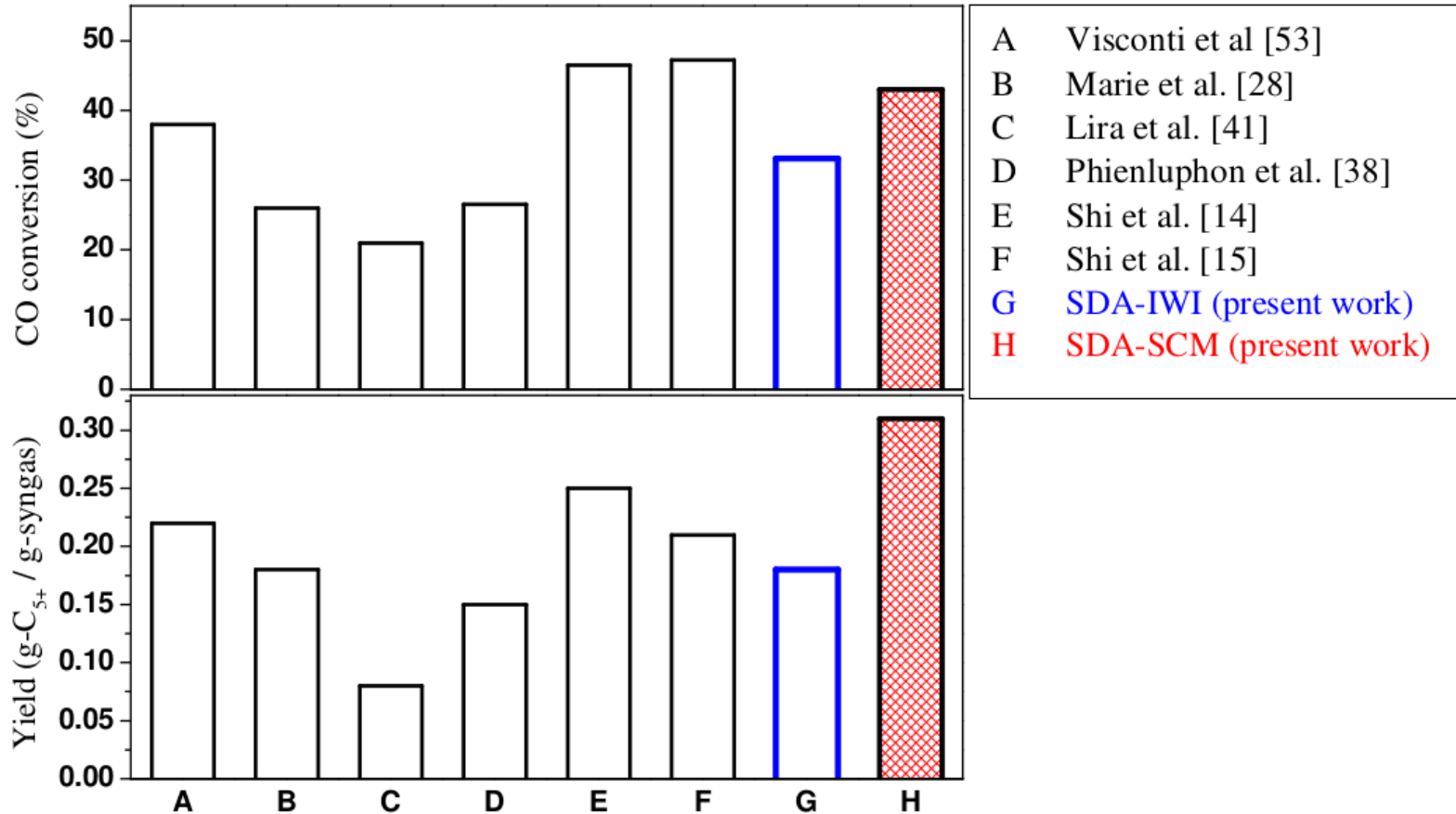

Novelty of the process

- Process of depositing metal loading in the range of 0.01 wt.% - 40 wt.% over support extrudes (particle sizes ranging from powders, to pellets and spheres, and as large as honeycomb monoliths) by simultaneously maintaining the structural integrity of the support material using solution combustion method.
- Apart from the catalyst depositing, the method also incorporates depositing catalytic promoters in the range of 0.01wt.% – 5 wt.%, which is the typical range. This process can be easily used to synthesize promoted catalysts similar to the primary metal deposition process.
- Capability to deposit metals without the need for reduction.
- Highly active cobalt based catalyst for Fischer Tropsch reaction with high yields corresponding to 0.31 gC₅₊/gcat at space velocities of 2610 (ml/h*gcat).

Typical range of operations for the catalysts developed

- Supported catalysts with metal loading ranging from 0.01 to 40 %
- Supports with particle size ranging from powders to pellets and spheres, as well as supports as large as monolith structures
- Application of SCM catalysts for FT reaction
- Fixed bed FT reactor
- High dispersion Cobalt catalysts for low temperature FT reaction
- Pressure 25 – 30 bar

Conclusion

- The invented method can be used to tailor catalyst properties which include, crystallite size, metal dispersion, metal-support interaction and most importantly the metal loading
- The synthesized catalysts can be applied to variety of industrial reactions spanning from petrochemical industries to pharmaceutical industries\
- In the current energy crisis scenario, large scale Biomass to Liquid plants installed should make use of highly active, stable and high-yielding catalysts for improved syngas utilization and higher product yield
- Most importantly, the catalyst synthesis procedure can be expanded for large scale bulk synthesis

Thank you